

SR...

SR... - 2RS

SPHERICAL PLAIN BEARING

-REQUIRING MAINTENANCE
-COUPLING:STEEL/STEEL

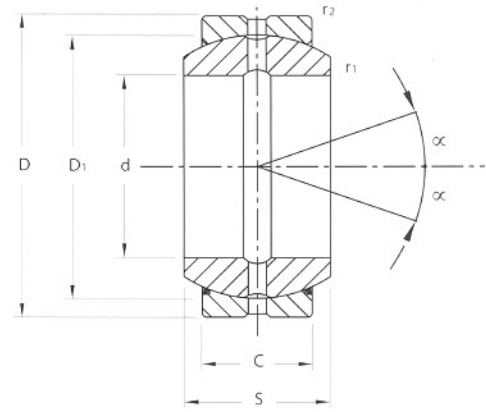

CODE BEARINGS WITHOUT PROTECTION RINGS	BEARINGS WITH PROTECTION RINGS	d	D	S	C	TOLERANCE				r1	R2
						d	D	S	C		
mm.											
SR 6 (1)		6	14	6	4	0 ± -0.008	0 ± -0.008	0 ± -0.12	0 ± -0.24	0.3	0.3
SR 8 (1)		8	16	8	5	0 ± -0.008	0 ± -0.008	0 ± -0.12	0 ± -0.24	0.3	0.3
SR 10 (1)		10	19	9	6	0 ± -0.008	0 ± -0.009	0 ± -0.12	0 ± -0.24	0.3	0.3
SR 12 (1)		12	22	10	7	0 ± -0.008	0 ± -0.009	0 ± -0.12	0 ± -0.24	0.3	0.3
SR 15	SR 15-2RS	15	26	12	9	0 ± -0.008	0 ± -0.009	0 ± -0.12	0 ± -0.24	0.3	0.3
SR 16		16	30	14	10	0 ± -0.008	0 ± -0.009	0 ± -0.12	0 ± -0.24	0.3	0.3
SR 17	SR 17-2RS	17	30	14	10	0 ± -0.008	0 ± -0.009	0 ± -0.12	0 ± -0.24	0.3	0.3
SR 20	SR 20-2RS	20	35	16	12	0 ± -0.010	0 ± -0.011	0 ± -0.12	0 ± -0.24	0.6	0.3
SR 25	SR 25-2RS	25	42	20	16	0 ± -0.010	0 ± -0.011	0 ± -0.12	0 ± -0.24	0.6	0.6
SR 30	SR 30-2RS	30	47	22	18	0 ± -0.010	0 ± -0.011	0 ± -0.12	0 ± -0.24	0.6	0.6
SR 35	SR 35-2RS	35	55	25	20	0 ± -0.012	0 ± -0.013	0 ± -0.12	0 ± -0.30	0.6	1.0
SR 40	SR 40-2RS	40	62	28	22	0 ± -0.012	0 ± -0.013	0 ± -0.12	0 ± -0.30	0.6	1.0
SR 45	SR 45-2RS	45	68	32	25	0 ± -0.012	0 ± -0.013	0 ± -0.12	0 ± -0.30	0.6	1.0
SR 50	SR 50-2RS	50	75	35	28	0 ± -0.012	0 ± -0.013	0 ± -0.12	0 ± -0.30	0.6	1.0
SR 60	SR 60-2RS	60	90	44	36	0 ± -0.015	0 ± -0.015	0 ± -0.15	0 ± -0.40	1.0	1.0
SR 70	SR 70-2RS	70	105	49	40	0 ± -0.015	0 ± -0.015	0 ± -0.15	0 ± -0.40	1.0	1.0
SR 80	SR 80-2RS	80	120	55	45	0 ± -0.015	0 ± -0.015	0 ± -0.15	0 ± -0.40	1.0	1.0
SR 90	SR 90-2RS	90	130	60	50	0 ± -0.020	0 ± -0.018	0 ± -0.20	0 ± -0.50	1.0	1.0
SR 100	SR 100-2RS	100	150	70	55	0 ± -0.020	0 ± -0.018	0 ± -0.20	0 ± -0.50	1.0	1.0
SR 110	SR 110-2RS	110	160	70	55	0 ± -0.020	0 ± -0.025	0 ± -0.20	0 ± -0.50	1.0	1.0
SR 120	SR 120-2RS	120	180	85	70	0 ± -0.020	0 ± -0.025	0 ± -0.20	0 ± -0.50	1.0	1.0
SR 140	SR 140-2RS	140	210	90	70	0 ± -0.025	0 ± -0.030	0 ± -0.25	0 ± -0.60	1.0	1.0
SR 160	SR 160-2RS	160	230	105	80	0 ± -0.025	0 ± -0.030	0 ± -0.25	0 ± -0.60	1.0	1.0
SR 180	SR 180-2RS	180	260	105	80	0 ± -0.025	0 ± -0.035	0 ± -0.25	0 ± -0.70	1.1	1.1
SR 200 (2)	SR 200-2RS	200	290	130	100	0 ± -0.030	0 ± -0.035	0 ± -0.30	0 ± -0.70	1.1	1.1
	SR 220-2RS (2)	220	320	135	100	0 ± -0.030	0 ± -0.040	0 ± -0.30	0 ± -0.80	1.1	1.1
	SR 240-2RS (2)	240	340	140	100	0 ± -0.030	0 ± -0.040	0 ± -0.30	0 ± -0.80	1.1	1.1
	SR 260-2RS (2)	260	370	150	110	0 ± -0.035	0 ± -0.040	0 ± -0.35	0 ± -0.80	1.1	1.1
	SR 280-2RS (2)	280	400	155	120	0 ± -0.035	0 ± -0.040	0 ± -0.35	0 ± -0.80	1.1	1.1
	SR 300-2RS (2)	300	430	165	120	0 ± -0.035	0 ± -0.045	0 ± -0.35	0 ± -0.90	1.1	1.1

(1) WITHOUT GREASE NIPPLE
(2) AVAILABILITY AND PRICE UPON REQUEST

NOTES: TO AVOID THE DAMAGE OR THE LOSS OF THE PROTECTION RINGS (-2RS) DO NOT ALLOW INNER BALL TO ROTATE OUT OF THE EXTERNAL HOUSING.

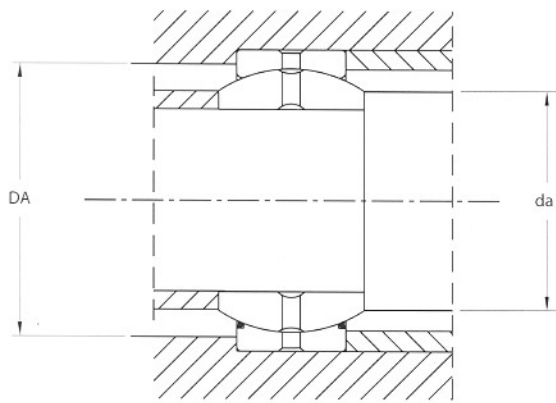

d	D1	OSCILLATION ANGLE α	LOAD FACTOR		RADIAL CLEARANCE	R1	R2	MOUNTING DIMENSIONS		WEIGHT
			DYNAM. C	STA. CO				da max.	DA min.	
mm.		GRADI	KN			mm.			Kg.	
6	10	13	3.4	17	0.032 - 0.068	0.3	0.3	8	9.6	0.00
8	13	15	5.5	27.5	0.032 - 0.068	0.3	0.3	10.2	12.5	0.00
10	16	12	8.15	40.5	0.032 - 0.068	0.3	0.3	13.2	15.5	0.01
12	18	11	10.8	54	0.032 - 0.068	0.3	0.3	14.9	17.5	0.01
15	22	8	17	85	0.040 - 0.082	0.3	0.3	18.4	21	0.02
16	25	10	21.2	106	0.040 - 0.082	0.3	0.3	20.7	24	0.03
17	25	10	21.2	106	0.040 - 0.082	0.3	0.3	20.7	24	0.04
20	29	9	30	146	0.040 - 0.082	0.6	0.3	24.1	27.5	0.06
25	35.5	7	48	240	0.050 - 0.100	0.6	0.6	29.3	33	0.11
30	40.7	6	62	310	0.050 - 0.100	0.6	0.6	34.2	38	0.14
35	47	6	80	400	0.050 - 0.100	0.6	1.0	39.7	44.5	0.22
40	53	7	100	500	0.060 - 0.120	0.6	1.0	45	51	0.30
45	60	7	127	640	0.060 - 0.120	0.6	1.0	50.7	57	0.40
50	66	6	156	780	0.060 - 0.120	0.6	1.0	55.9	63	0.54
60	80	6	245	1220	0.060 - 0.120	1.0	1.0	66.8	75	1.00
70	92	6	315	1560	0.072 - 0.142	1.0	1.0	77.8	87	1.50
80	105	6	400	2000	0.072 - 0.142	1.0	1.0	89.4	99	2.20
90	115	5	490	2450	0.072 - 0.142	1.0	1.0	98.1	108	2.70
100	130	7	610	3050	0.085 - 0.165	1.0	1.0	109.5	123	4.30
110	140	6	655	3250	0.085 - 0.165	1.0	1.0	121.2	134	4.70
120	160	6	950	4750	0.085 - 0.165	1.0	1.0	135.5	150	8.00
140	180	7	1080	5400	0.085 - 0.165	1.0	1.0	155.8	173	11.00
160	200	8	1370	6800	0.100 - 0.192	1.0	1.0	170.2	191	13.50
180	225	6	1530	7650	0.100 - 0.192	1.1	1.1	198.9	219	18.50
200	250	7	2120	10600	0.100 - 0.192	1.1	1.1	213.5	239	28.00
220	275	8	2320	11600	0.100 - 0.192	1.1	1.1	239.5	267	35.50
240	300	8	2550	12700	0.100 - 0.192	1.1	1.1	265.3	295	40.00
260	325	7	3050	15300	0.110 - 0.214	1.1	1.1	288.3	319	50.00
280	350	6	3550	18000	0.110 - 0.214	1.1	1.1	313.8	342	64.00
300	375	7	3800	19000	0.110 - 0.214	1.1	1.1	336.7	370	75.00