

BALL BEARINGS

KH 200 AE type
 KHR 200 AE type
 Light Duty
 Eccentric Collar Locking

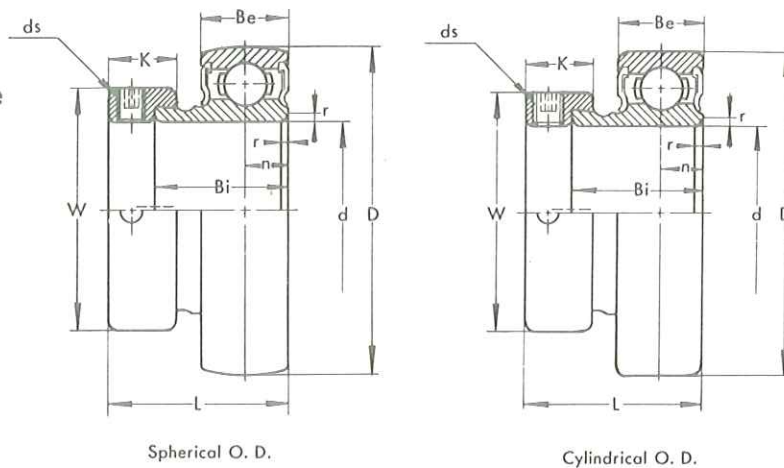

《Metric series》

Bearing No.		Dimensions (mm)											Basic Load Rating (kgf)		Weight (kg)
Spherical O.D.	Cylindrical O.D.	d	D	L	B _i	B _e	r	T	n	W	K	d _s	Dynamic C	Static C ₀	
KH 201 AE	KHR 201 AE	12	40	28.6	19.1	12	1	3.6	6.5	28.6	13.5	M 6×0.75	975	460	0.12
KH 202 AE	KHR 202 AE	15	40	28.6	19.1	12	1	3.6	6.5	28.6	13.5	M 6×0.75	975	460	0.11
KH 203 AE	KHR 203 AE	17	40	28.6	19.1	12	1	3.6	6.5	28.6	13.5	M 6×0.75	975	460	0.1
KH 204 AE	KHR 204 AE	20	47	31	21.5	14	1.5	4.1	7.5	33.3	13.5	M 6×0.75	1310	635	0.16
KH 205 AE	KHR 205 AE	25	52	31	21.5	15	1.5	4.1	7.5	38.1	13.5	M 6×0.75	1430	730	0.2
KH 206 AE	KHR 206 AE	30	62	35.7	23.8	16	1.5	4.9	9	44.5	15.9	M 8×1	2000	1050	0.31
KH 207 AE	KHR 207 AE	35	72	38.9	25.4	17	2	5.4	9.5	55.6	17.5	M10×1.25	2640	1430	0.49
KH 208 AE	KHR 208 AE	40	80	43.7	30.2	18	2	5.9	11	60.3	18.3	M10×1.25	2990	1650	0.62
KH 209 BE	KHR 209 BE	45	85	43.7	30.2	19	2	6.2	11	63.5	18.3	M10×1.25	3350	1890	0.65
KH 210 BE	KHR 210 BE	50	90	43.7	30.2	20	2	6.5	11	69.9	18.3	M10×1.25	3600	2110	0.75
KH 211 BE	KHR 211 BE	55	100	48.4	32.5	21	2.5	7	12	76.2	20.7	M12×1.5	4400	2670	0.94

《Inch series》

Bearing No.		Dimensions (in)											Basic Load Rating (lbf)		Weight (lb)
Spherical O.D.	Cylindrical O.D.	d	D	L	B _i	B _e	r	T	n	W	K	d _s (UNF)	Dynamic C	Static C ₀	
KH 201-8AE	KHR 201-8AE	1/2	1.5748	1 1/8	0.752	0.472	0.039	0.142	0.256	1 1/8	1 1/32	1/4-28	2150	1010	0.26
KH 202-9AE	KHR 202-9AE	9/16													
KH 202-10AE	KHR 202-10AE	5/8													
KH 203-11AE	KHR 203-11AE	11/16	1.8504	1 7/32	0.846	0.551	0.059	0.161	0.295	1 5/16	1 1/32	1/4-28	2890	1400	0.35
KH 204-12AE	KHR 204-12AE	3/4													
KH 205-14AE	KHR 205-14AE	7/8													
KH 205-15AE	KHR 205-15AE	15/16	2.0472	1 7/32	0.846	0.591	0.059	0.161	0.295	1 1/2	1 1/32	1/4-28	3150	1610	0.44
KH 205-16AE	KHR 205-16AE	1													
KH 206-18AE	KHR 206-18AE	1 1/8													
KH 206-19AE	KHR 206-19AE	1 3/16	2.4409	1 1/2	0.938	0.630	0.059	0.193	0.354	1 3/4	5/8	5/16-24	4410	2310	0.68
KH 206-20AE	KHR 206-20AE	1 1/4													
KH 207-20AE	KHR 207-20AE	1 1/4													
KH 207-21AE	KHR 207-21AE	1 5/16	2.8346	1 1/2	1.000	0.669	0.079	0.213	0.374	2 3/16	1/16	3/8-24	5820	3150	1.08
KH 207-22AE	KHR 207-22AE	1 3/8													
KH 207-23AE	KHR 207-23AE	1 7/16													
KH 208-24AE	KHR 208-24AE	1 1/2													
KH 208-25AE	KHR 208-25AE	1 9/16	3.1496	1 1/2	1.188	0.709	0.079	0.232	0.433	2 3/8	3/32	3/8-24	6590	3640	1.37
KH 209-26BE	KHR 209-26BE	1 5/8													
KH 209-27BE	KHR 209-27BE	1 11/16													
KH 209-28BE	KHR 209-28BE	1 3/4	3.3465	1 1/2	1.188	0.748	0.079	0.244	0.433	2 1/2	3/32	3/8-24	7390	4170	1.43
KH 210-30BE	KHR 210-30BE	1 7/8													
KH 210-31BE	KHR 210-31BE	1 15/16													
KH 211-32BE	KHR 211-32BE	2	3.9370	1 1/2	1.281	0.827	0.098	0.276	0.472	3	1/16	7/16-20	9700	5880	2.07
KH 211-34BE	KHR 211-34BE	2 1/8													
KH 211-35BE	KHR 211-35BE	2 3/16													