

UC 300 type

Heavy Duty
Set-screw Locking

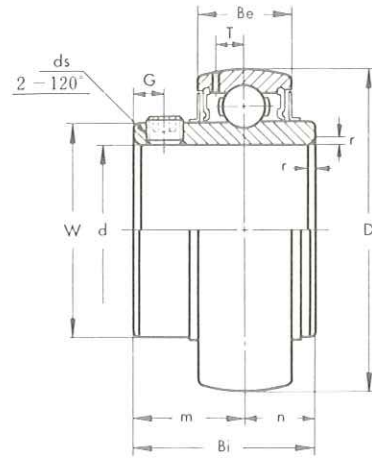

《Metric series》

Bearing No.	Dimensions mm											Basic Load Rating kg		Weight kg
	d	D	Bi	Be	r	n	m	G	ds	T	W	Dynamic C	Static Co	
UC 305	25	62	38	21	2	15	23	6	M 6×0.75	6.1	36.9	2170	1090	0.44
UC 306	30	72	43	23	2	17	26	6	M 6×0.75	6.7	45	2730	1420	0.56
UC 307	35	80	48	25	2.5	19	29	8	M 8×1	7.4	50.5	3400	1820	0.71
UC 308	40	90	52	27	2.5	19	33	10	M10×1.25	8.2	56	4150	2270	1.00
UC 309	45	100	57	30	2.5	22	35	10	M10×1.25	9	63	5250	3050	1.28
UC 310	50	110	61	32	3	22	39	12	M12×1.5	10	70.5	6300	3650	1.65
UC 311	55	120	66	34	3	25	41	12	M12×1.5	10.7	76.5	7300	4250	2.07
UC 312	60	130	71	36	3.5	26	45	12	M12×1.5	11.5	82.5	8300	4900	2.59
UC 313	65	140	75	38	3.5	30	45	12	M12×1.5	12.2	88.5	9450	5650	3.15
UC 314	70	150	78	40	3.5	33	45	12	M12×1.5	13	95.2	10600	6450	3.83
UC 315	75	160	82	42	3.5	32	50	14	M14×1.5	13.8	101.5	11600	7200	4.59
UC 316	80	170	86	44	3.5	34	52	14	M14×1.5	14.5	108	12500	8150	5.40
UC 317	85	180	96	46	4	40	56	16	M16×1.5	15	114.5	13500	9100	6.58
UC 318	90	190	96	48	4	40	56	16	M16×1.5	15.9	121	14600	10100	7.34
UC 319	95	200	103	50	4	41	62	16	M16×1.5	16.7	127.5	15600	11100	8.70
UC 320	100	215	108	54	4	42	66	18	M18×1.5	18	135.5	17700	13300	10.80
UC 321	105	225	112	56	4	44	68	18	M18×1.5	19	142	18700	14500	12.20
UC 322	110	240	117	60	4	46	71	18	M18×1.5	21	152	20900	17000	14.30
UC 324	120	260	126	64	4	51	75	18	M18×1.5	22	165	21100	17000	18.50
UC 326	130	280	135	68	5	54	81	20	M20×1.5	23	178	23400	19600	23.00
UC 328	140	300	145	73	5	59	86	20	M20×1.5	25	191.5	26000	22400	28.50

*《Inch series》

Bearing No.	Dimensions in.											Basic Load Rating lb.		Weight lb.
	d	D	Bi	Be	r	n	m	G	ds(UNF)	T	W	Dynamic C	Static Co	
UC 305-14 305-16	7/8 1	2.4409	1.496	0.827	0.079	0.591	0.906	0.236	1/4-28	0.240	1.453	4780	2400	0.97
UC 306-18	1 1/8	2.8346	1.693	0.906	0.079	0.669	1.024	0.236	1/4-28	0.264	1.772	6020	3130	1.23
UC 307-20 307-22	1 1/4 1 3/8	3.1496	1.890	0.984	0.098	0.748	1.142	0.315	5/16-24	0.291	1.988	7500	4010	1.56
UC 308-24	1 1/2	3.5433	2.047	1.063	0.098	0.748	1.299	0.394	3/8-24	0.323	2.205	9150	5000	2.20
UC 309-26 309-28	1 5/8 1 3/4	3.9370	2.244	1.181	0.098	0.866	1.378	0.394	3/8-24	0.354	2.480	11570	6720	2.82
UC 310-30	1 7/8	4.3307	2.402	1.260	0.118	0.866	1.535	0.472	7/16-20	0.394	2.776	13900	8050	3.64
UC 311-32 311-34	2 2 1/8	4.7244	2.598	1.339	0.118	0.984	1.614	0.472	7/16-20	0.421	3.012	16100	9370	4.56
UC 312-36 312-38	2 1/4 2 3/8	5.1181	2.795	1.417	0.138	1.024	1.772	0.472	1/2-20	0.453	3.248	18300	10800	5.71
UC 313-40	2 1/2	5.5118	2.953	1.496	0.138	1.181	1.772	0.472	1/2-20	0.480	3.484	20800	12500	6.94
UC 314-44	2 3/4	5.9055	3.071	1.575	0.138	1.299	1.772	0.472	1/2-20	0.512	3.748	23400	14200	8.44
UC 315-48	3	6.2992	3.228	1.654	0.138	1.260	1.969	0.551	9/16-18	0.543	3.996	25600	15900	10.12
UC 316-50	3 1/8	6.6929	3.386	1.732	0.138	1.339	2.047	0.551	9/16-18	0.571	4.252	27600	18000	11.90
UC 317-52	3 1/4	7.0866	3.780	1.811	0.157	1.575	2.205	0.630	5/8-18	0.591	4.508	29800	20100	14.50
UC 318-56	3 1/2	7.4803	3.780	1.890	0.157	1.575	2.205	0.630	5/8-18	0.626	4.764	32200	22300	16.18
UC 319-60	3 3/4	7.8740	4.055	1.969	0.157	1.614	2.441	0.630	5/8-18	0.657	5.020	34400	24500	19.17
UC 320-64	4	8.4646	4.252	2.126	0.157	1.654	2.598	0.709	3/4-16	0.709	5.335	39000	29300	23.80